

Deck Coextruido WPC ofrece una apariencia natural mate con un acabado lujoso y de alta resistencia al deslizamiento y fuego. Es ideal para exteriores en espacios residenciales y comerciales.

COMPOSICIÓN:

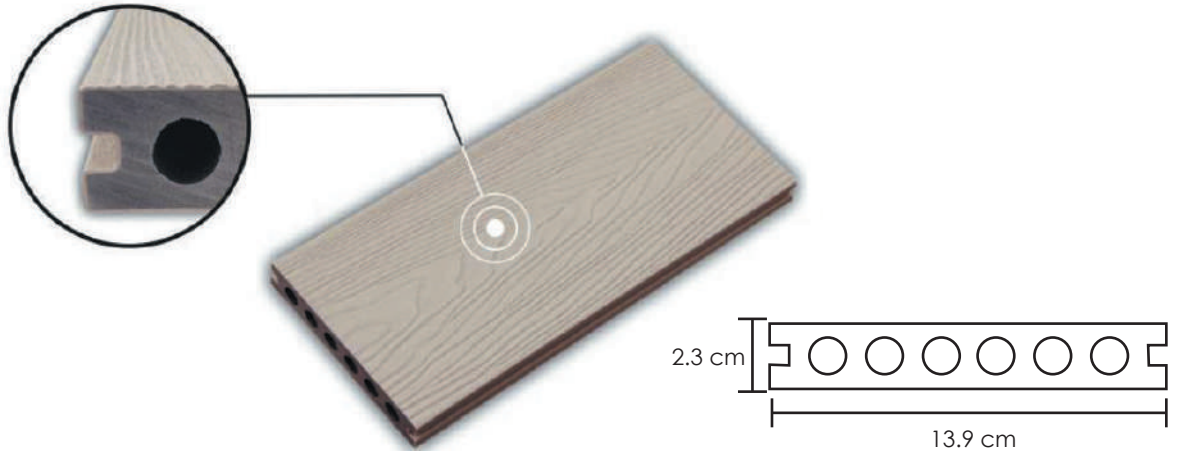

FICHA TÉCNICA:

GROSOR	230 mm
MEDIDAS	13.9 cm x 2.90 cm
m ² POR PIEZA	0.4031 m ²

INSTALACIÓN:

Una instalación con grapas y tornillos



VENTAJAS

- SIN MANCHAS
- SIN MARCAS
- ANTIDERRAPANTE
- SIN FILTRACIONES
- ANTIBACTERIAL
- RESISTENCIA AL FUEGO
- INSTALACIÓN RÁPIDA
- PISO CONFORTABLE
- NO SE DAÑA
- NO REQUIEREN MANTENIMIENTO
- PETFRIENDLY
- TONO SIEMPRE IGUAL
- FÁCIL LIMPIEZA
- NO SE DECOLORA
- AISLANTE ACÚSTICO
- DISEÑOS Y TEXTURAS ÚNICAS



TEST CERTIFICATE PENDULUM SLIP TESTING IN ACCORDANCE WITH BS 7976-2:2002



PENDULUM SLIP TESTING

TEST DESCRIPTION: Pendulum Slip Testing done in accordance with BS 7976-2:2002. The board was tested both sides, dry and wet, 8 times at 0°, 45° and 90°, with the mean of the last 5 results recorded.

REF NO.: DR-5289
JOB NO.: P10044
CERTIFICATE NO.: IC9507
TEST PRODUCT: HR DEK 140

DATE TESTED: 30th October 2020
DATE REPORTED: 2nd November 2020
CERTIFICATE DATE: 2nd November 2020

TEST RESULTS:

		PTV (Pendulum Test Value)									
		Test No.	1	2	3	4	5	6	7	8	Mean
DARK SIDE DRY	0°		82	86	86	90	92	92	90	93	91.4
	45°		91	94	95	97	96	96	97	97	96.6
	90°		95	96	96	96	96	96	97	97	96.4
		Test No.	1	2	3	4	5	6	7	8	Mean
DARK SIDE WET	0°		54	53	53	53	53	53	52	53	52.8
	45°		59	60	60	61	61	62	62	61	61.4
	90°		60	61	61	61	61	61	61	61	61
		Test No.	1	2	3	4	5	6	7	8	Mean
LIGHT SIDE DRY	0°		88	90	90	91	91	91	92	91	91.2
	45°		89	90	92	92	93	93	94	94	93.2
	90°		88	96	97	97	98	98	98	99	98
		Test No.	1	2	3	4	5	6	7	8	Mean
LIGHT SIDE WET	0°		44	44	44	42	42	42	42	41	41.8
	45°		58	57	58	58	58	57	57	58	57.6
	90°		60	61	61	61	61	61	61	62	61.2





Total Quality. Assured.

Intertek Report No. 210727007SHF-002

Test Items, Method and Results:

Test Item: Resistance to artificial weathering - Xenon-arc Lamps

Test Sample: Coextrusion decking

Test Method: ISO 4892-2:2013 Cycle 1

Exposure cycle:

1) 102 min light at (65±3)°C, Black-standard-temperature, Relative humidity (50±10)%, Irradiance: 0.51 ± 0.02 W/(m²·nm) at 340 nm.

2) 18 min light and water spray, Irradiance: 0.51 ± 0.02 W/(m²·nm) at 340 nm.

Test Duration: 1000 hours

Test Result:

Exposure time	ΔL*	Δa*	Δb*	ΔE*	Grey scale	Observation
300 hours	-0.62	0.20	-0.06	0.66	4-5	Part showed slight color change
500 hours	-0.57	0.14	-0.35	0.68	4-5	Part showed slight color change
800 hours	0.18	-0.15	-0.82	0.85	4-5	Part showed slight color change, there were little white precipitates on the surface of sample.
1000 hours	2.39	-0.92	-2.23	3.40	3	Part showed some color change, and there were small amount of white precipitates on the surface of sample

Test Items	Test Method	Test Results	Test requirements	Verdict
Moisture resistance under cyclic test conditions	EN 15534-1:2014 Section 8.3.2 EN 15534-4: 2014 Section 4.5.5	Original Bending Strength: 29.3 MPa After exposure, Mean Bending Strength: 27.4 MPa Decrease: 7 % Min Bending Strength: 26.8 MPa Decrease: 9 %	Decrease of bending strength, Mean ≤ 20 % Max. ≤ 30 %	Pass

Test Items	Test Method	Test Results	Test requirements	Verdict
Slipperiness (Pendulum test)	EN 15534-1:2014 Section 6.4.2 CEN/TS 15676:2007 EN 15534-4: 2014 Section 4.4	Longitudinal direction: Mean: 103 Min.: 102 Horizontal direction: Mean: 108 Min.: 107	Pendulum value ≥ 36	Pass

Test Items	Test Method	Test Results	Test requirements	Verdict
Flexural properties	EN 15534-1:2014 Annex A EN 15534-4: 2014 Section 4.5.2	Bending Strength: 29.3 MPa Modulus of elasticity: 2790 MPa Maximum load: Mean: 4168 N Min.: 4037 N Deflection at 500N: Mean: 0.98 mm Max.: 1.26 mm	Flexural properties -F'max: Mean ≥ 3300 N Min. ≥ 3000 N -Deflection under a load of 500 N Mean $\leq 2,0$ mm Max. $\leq 2,5$ mm	Pass

Test Items	Test Method	Test Results	Test requirements	Verdict
Resistance to artificial weathering	EN 15534-1:2014 Section 8.1 EN 15534-4: 2014 Section 4.5.5 ISO 4892-2: 2013, cycle 1	After 2000h exposure: $\Delta L^* = 0.94$ $\Delta a^* = -0.34$ $\Delta b^* = -0.49$ $\Delta E^* = 1.12$ Grey Sale= 4-5	$\Delta L^*, \Delta a^*$ and Δb^* shall be delared	N/A

Test Items	Test Method	Test Results	Test requirements	Verdict
Moisture resistance under cyclic test conditions	EN 15534-1:2014 Section 8.3.2 EN 15534-4: 2014 Section 4.5.5	Original Bending Strength: 29.3 MPa After exposure, Mean Bending Strength: 27.4 MPa Decrease: 7 % Min Bending Strength: 26.8 MPa Decrease: 9 %	Decrease of bending strength, Mean ≤ 20 % Max. ≤ 30 %	Pass

Test Items	Test Method	Test Results	Applicant's requirement	Verdict
Swelling and water absorption (28 days immersion)	EN 15534-1:2014 Section 8.3.1 EN 15534-4: 2014 Section 4.5.5	Mean Swelling: 1.04 % in thickness 0.11 % in width 0.05 % in length Max. Swelling: 1.15 % in thickness 0.13 % in width 0.06 % in length Water absorption: Mean: 0.32 % Max.: 0.32 %	Means swelling: ≤ 4 % in thickness ≤ 0,8 % in width ≤ 0,4 % in length Max. swelling: ≤ 5 % in thickness ≤ 1,2 % in width ≤ 0,6 % in length Water absorption: Mean ≤ 7 % Max. ≤ 9 %	Pass

Tensile strength	Failure model
Mean: 2.9 N/mm ²	Fracture within the glue line

Parameter	Specimen 1	Specimen 2	Specimen 3
Mass/Weight loss, (mg)	50.2	57.1	57.3
Average value, (mg)	54.8		



1.- Análisis de contrapiso o firme

La base donde será instalando el Deck debe estar siempre en perfectas condiciones. El firme debe estar:

- LIMPIO
- SECO
- ESTABLE
- PULIDO
- SOLIDO

Es necesario que el firme en donde se fijaran los bastidores tenga una pendiente para evitar encharcamientos (por lo menos 5cm)

Los bastidores se atornillan al firme (concreto) dejando un espacio de 35 cm entre cada uno.

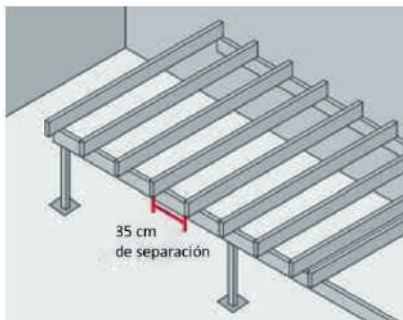

Cada tornillo se coloca con un espacio de 35 cm adjuntado las grapas correspondientes entre tornillo y bastidor

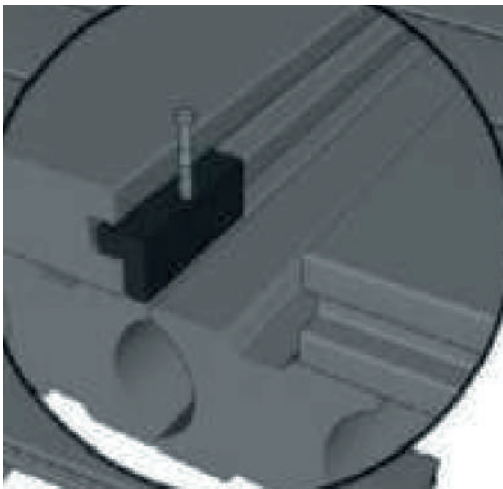

Las grapas servirán para sujetar una duela con otra.

La separación de una y otra duela la marcará la grapa

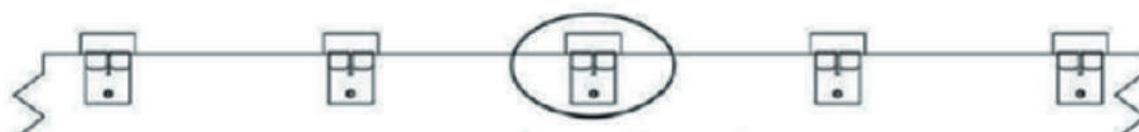

1.1.- Análisis de contrapiso o firme si utilizamos bastidores de herrería

Para poder realizar una estructura de PTR (bastidores) es necesario considerar un trabajo de herrería el cual se determinará conforme a las necesidades de cada proyecto.

Consideraciones generales

Una vez colocado el bastidor las duelas se atornillan a estos en sentido contrario con un diseño escalonado para mayor funcionalidad

Es necesario contar con ciertas herramientas para poder hacer las terminaciones adecuadas (caladora, ingleteadora, mesa de corte plano, atornillador eléctrico)

Instalación

1. Se comienza la instalación a partir del muro colocando la primer pieza o duela completa en sentido contrario al bastidor, se ajusta sobre el mismo con grapas y tornillos
2. Se atornilla la grapa al bastidor para sujetar la duela y así poder ensamblar la duela consecutiva con la misma grapa
3. Una vez colocada y sujeta la primera duela se recomienda cortar por la mitad la segunda esto hará que la instalación lleve un diseño escalonado lo que le dará mayor funcionalidad y visualmente tendrá un efecto positivo.
4. Repita el proceso de corte e instalación cada tercera duela y el sistema escalonado irá fluyendo conforme el área lo requiera
5. Para terminar la instalación la última pieza se ajusta al área (remate)